



When to Use an OTDR and How to Use it Correctly

Christian Schillab

Product Application Specialist EMEA (Retired)

Fluke Networks





Agenda

- Fiber Issues
- Tools to use before you go to an OTDR
- Common mistakes to avoid: **If you are going to use an OTDR, use it correctly**
 - Even if you are not a fiber expert
- Examples of traces and issues that affect them



Fiber Issues

- Link doesn't work
- No Link Light
- Too much loss
- CRC/FCS errors
- Contractual obligations
 - New Construction
 - Required documentation

Propagation Delay (ns)		1376	
<input type="checkbox"/>	Interface	Total Packets Received Without Errors	Packets Received With Errors
<input type="checkbox"/>	g1	9156	8538
Limit (dB)		1.78	1.78
Margin (dB)		-29.02	-27.62
Reference (dBm)		-2.39	-2.38

C. Testing shall be carried out in accordance with the condition and polarity of the installed cable plant with an optical time domain reflectometer (OTDR). The condition of the fiber end faces shall



Tools to use before an OTDR for Troubleshooting

- VFL – Is there light coming out? Is it coming out of the right fiber? Distance limitation
 - Use Sunlight if needed (and available)
- Inspection – How dirty is it? Inspect again after cleaning and cleaning

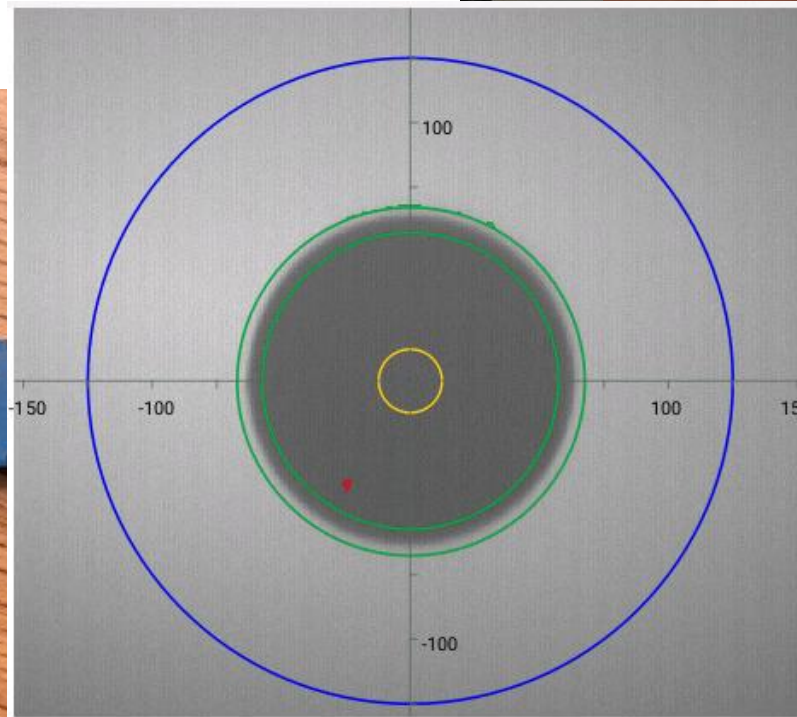
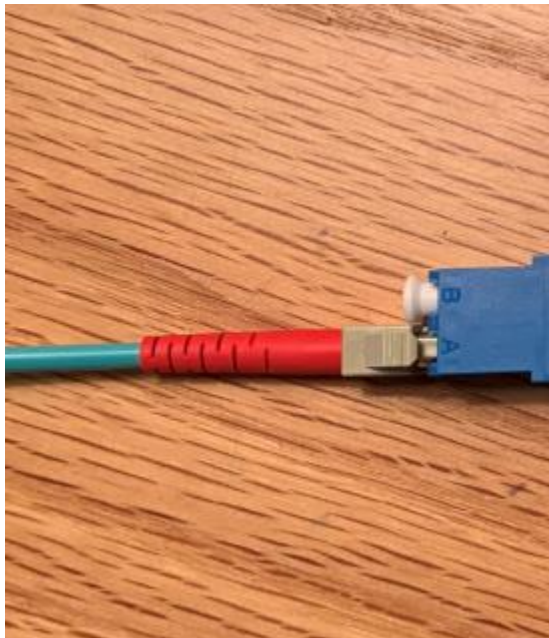



Tools to use before an OTDR for Troubleshooting

- VFL – Is there light coming out? Is it coming out of the right fiber?
- Inspection – How dirty is it? Inspect again after cleaning. Perhaps a whole slide on cleaning
- Live Fiber Detector – Is there light in the fiber

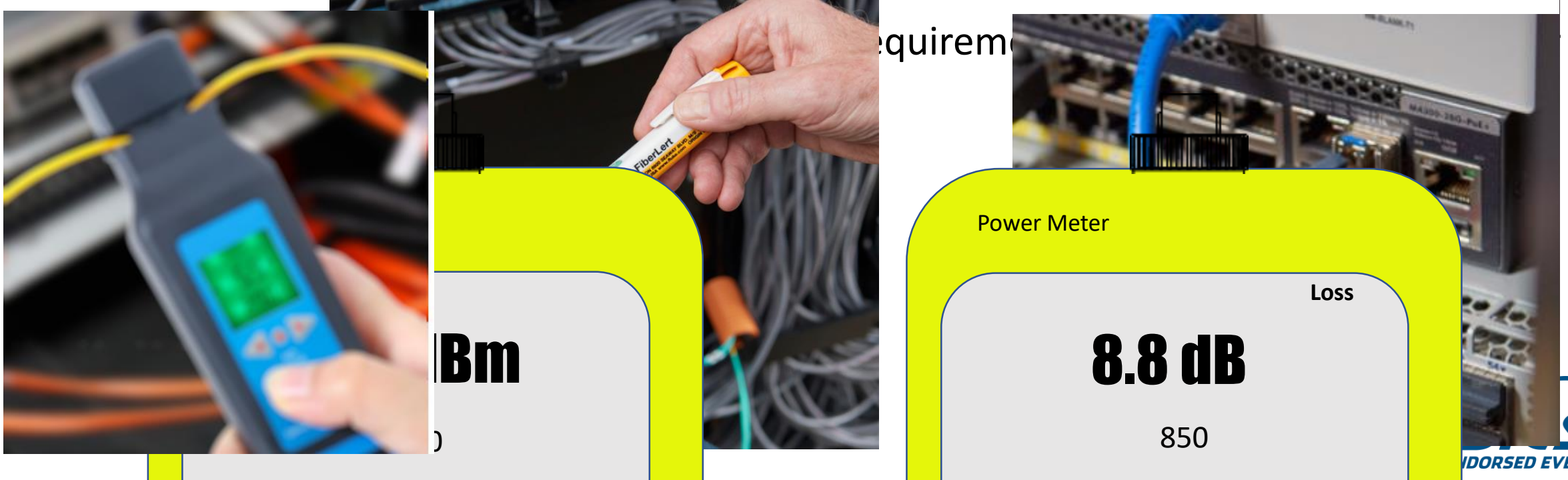



So, The Problem Hasn't Gone Away
and it is Time to Get the OTDR



How does an Optical Time Domain Reflectometer work

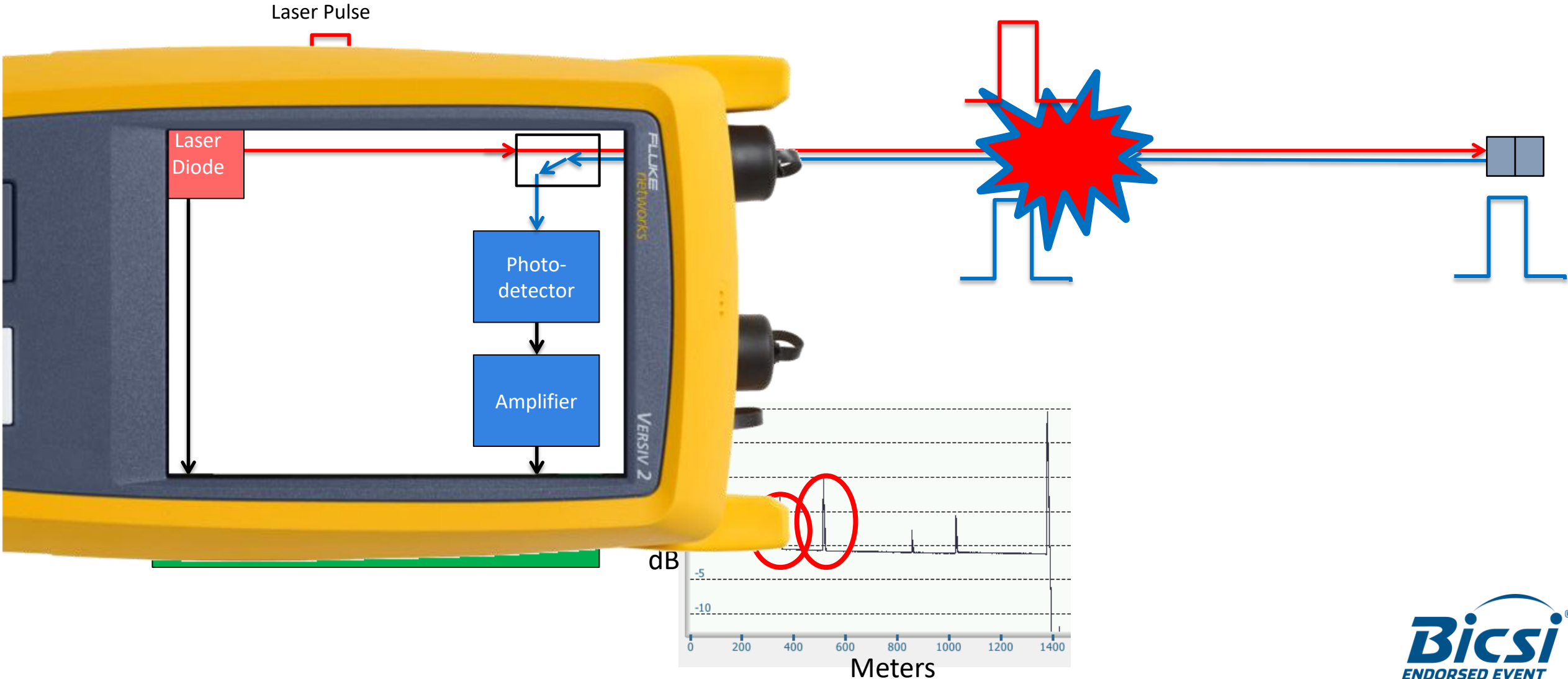



An OTDR Trace

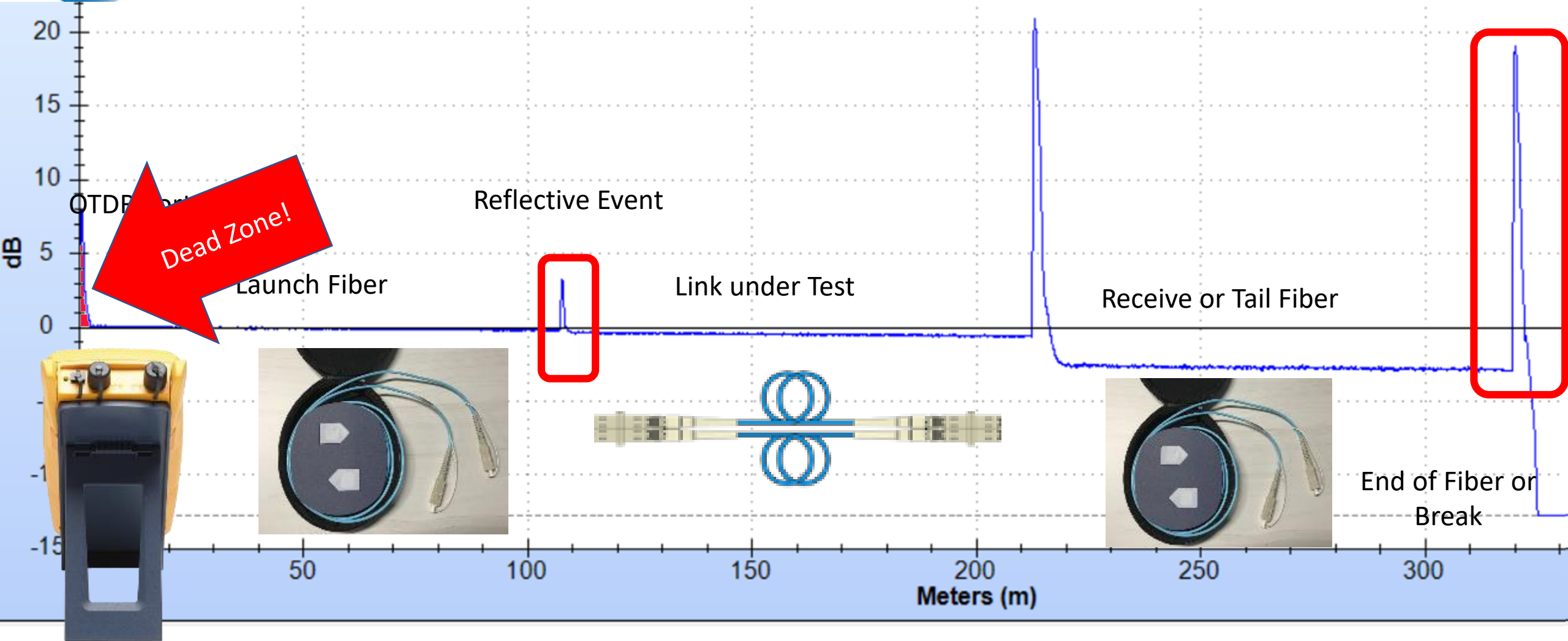



Loss Measurement on an OTDR

- To measure the loss, we will set a cursor before and after an event
- Here is the before
- And here it is set after
- Here are the details of the loss
- We are measuring the loss on the vertical scale
- Don't be scared! The expert module in the OTDR will calculate all of this for us automatically
- Here is the loss value, our limit is 0.75 dB so this is a failing event





You don't have to be an Expert at Reading Traces to Use an OTDR!

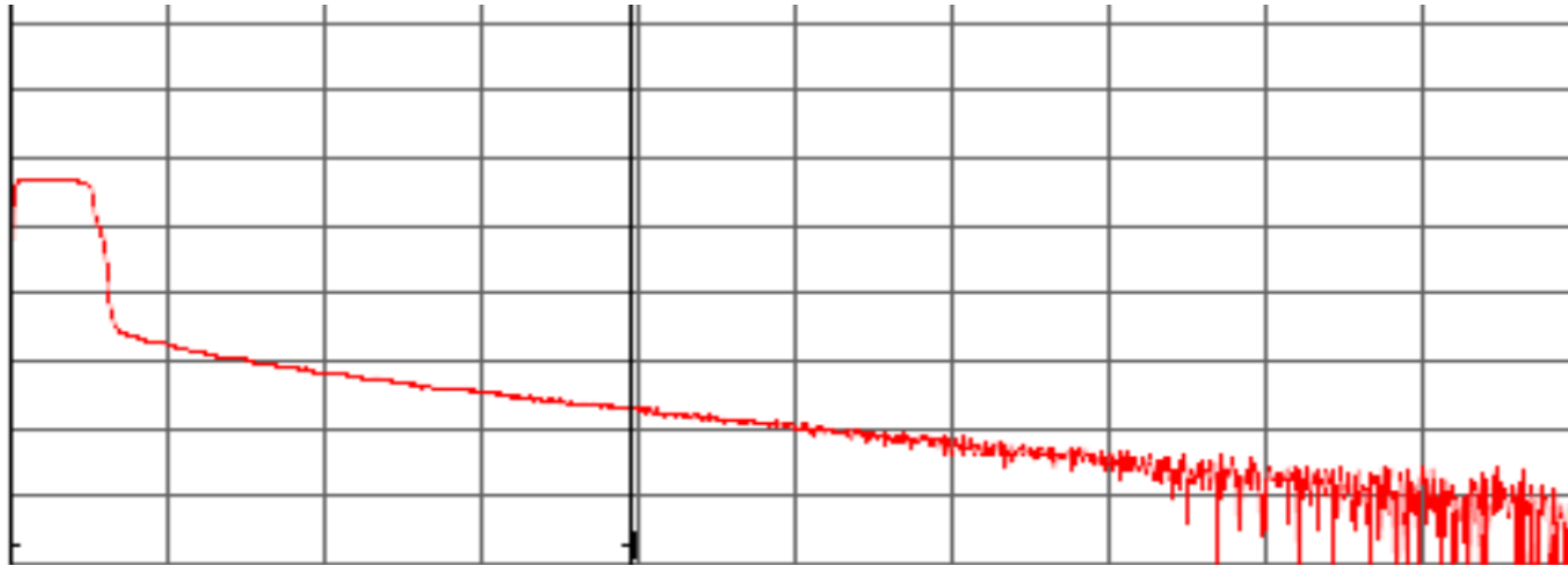



Here are the Best Practices to get a good Trace – These will help whoever has to read the trace

Expert modules are great, but, if you don't set up the test correctly, the expert module can't overcome these problems

- 1) A Clean Port on the OTDR
- 2) Verify the launch and tail before testing, and save that test
- 3) Use a Launch fiber to see the first connection
 - Don't add a short adapter cable to the end of the launch fiber!
- 4) Use a Tail Fiber to see the last connection
- 5) Correct IOR to find correct length to an event
- 6) Need to test the fiber in both directions – preferably without disconnecting the launch and tail fibers
- 7) Use a limit that includes pass/fail for reflectance



Be Careful with the Port of your OTDR

- Inspect the port before testing
 - Clean if necessary
- Test your launch and tail fibers before testing
 - Save that test



reduce
st in the
the tester
rement



OTDR Port at 0.00 m



Example of Trace with poor quality OTDR Port

- Look at all of those events!
- Even a Hidden Event! (what is that?)
- I always start with the port
- If the Window is dirty, it is hard to see outside
- That reflectance is terrible

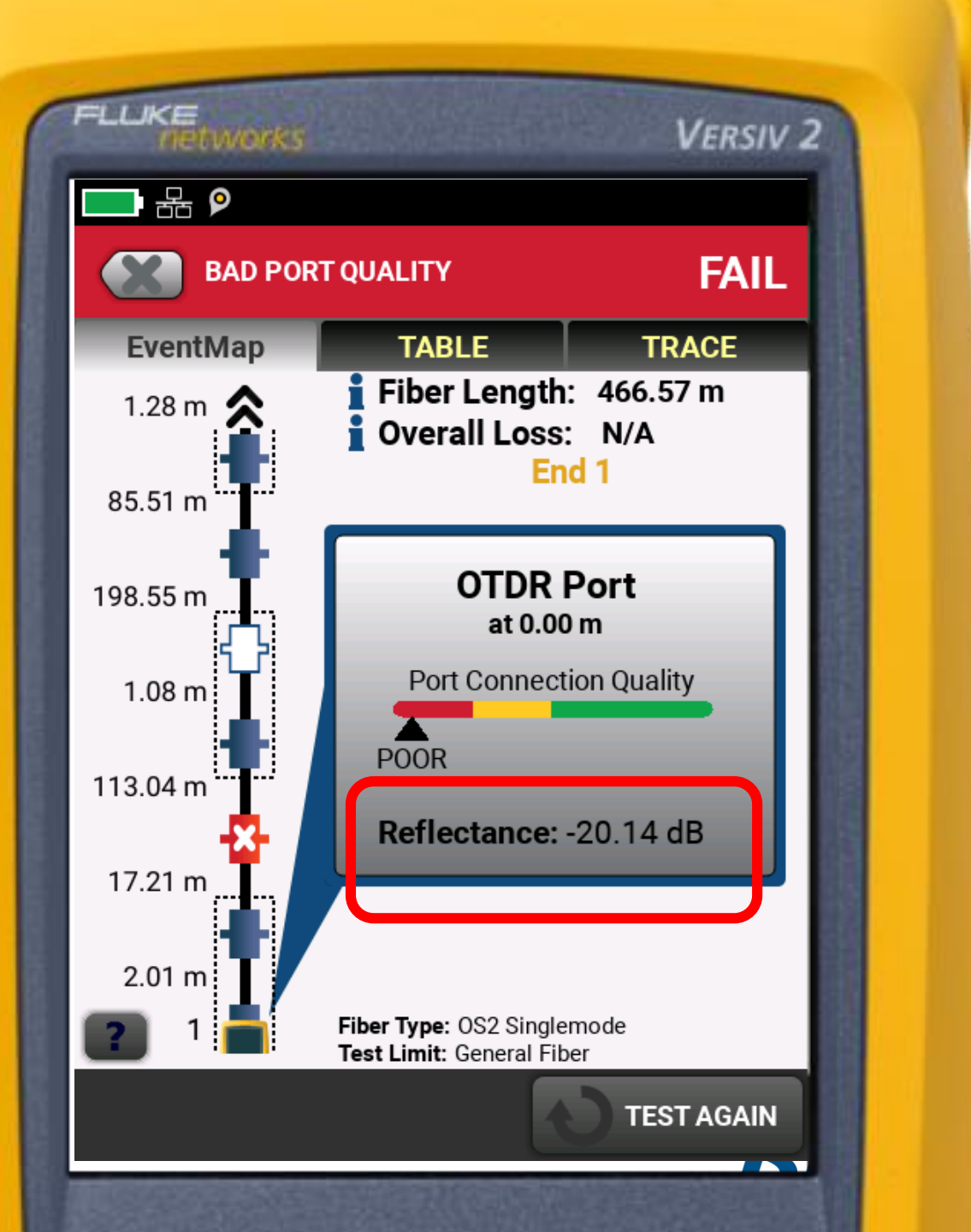



A Quick Study on Pulse Width and Dead Zones

Longer Pulse Widths Make Larger Dead Zones
You need a longer pulse to 'see' a longer fiber
Or through a Splitter (PON and PON LAN)



What problem are you trying to solve? Do you need a launch fiber?

- There is no light coming out of the fiber and I need to quickly find the distance to open
- We put a splice into the fiber at X thousand feet and we need to show it is a good splice
 - Quick explanation of “Span”
- There is an issue, and the fiber is being blamed. I need to show it isn't the fiber.
 - Fully characterize the link
- I am contractually obligated to deliver a Tier II test report on a fiber



Dead Zone Vs Pulse Width

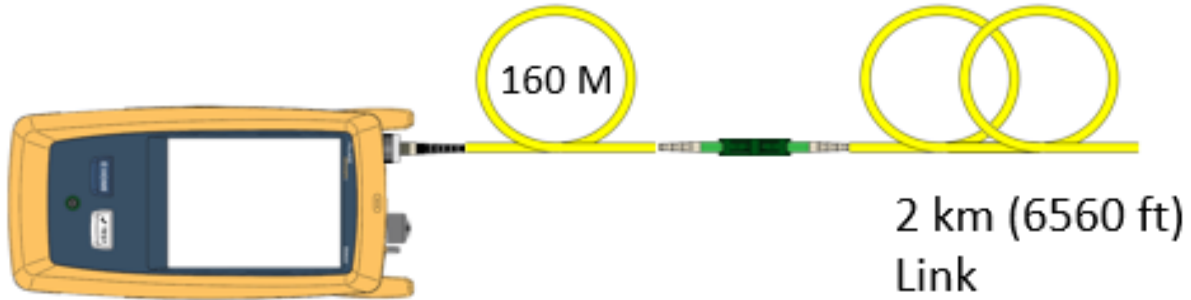

- Here is 50 ns, about 15 meters
- 500 ns pulse is about 60 meters
 - Notice the first connector at 160
 - We still see the first connection in the 'expert module'
- 1000 ns pulse, about 145 m dead zone
 - We have lost the first connection
- At 5000 ns We are losing our 2000 m link

Longer Pulse makes Longer Dead Zone





How Long Should my Launch / Tail Fiber Be?

Long enough for the pulse to fit

- As a guide only, for Single Mode – Your results may vary

Maximum length of Link (km)		Typical Pulse Width (ns)	Minimum Launch & Tail Cord Length (meters)*
1310 nm	1550 nm		
0 to 35	0 to 50	≤ 1,000	160
35 to 45	50 to 65	3,000	400
45 to 50	65 to 75	10,000	1,000
≥ 50	≥ 75	20,000	2,400

* For fiber with typical attenuation (≤ 0.35 dB/km at 1310 nm; ≤ 0.2 dB/km at 1550 nm) and event loss less than 0.8 dB



Example of Trace with short adapter cord on end of launch fiber

- Back to a Hidden Event
- Your Launch (and Tail) fibers must have the right connector. Don't add a short hybrid cord to adapt
- On the Trace, we can see...
- The distinctive “double bump” of two connectors
- Since the trace did not “recover” between them, here, the loss of the second event cannot be measured, hence, the “hidden” event
- In this example, the loss of the two connectors together exceeds the custom 0.50 dB limit and it is failing





OTDR Testing of MPO with Connector Loss and Reflectance Requires a Launch and Receive Fiber

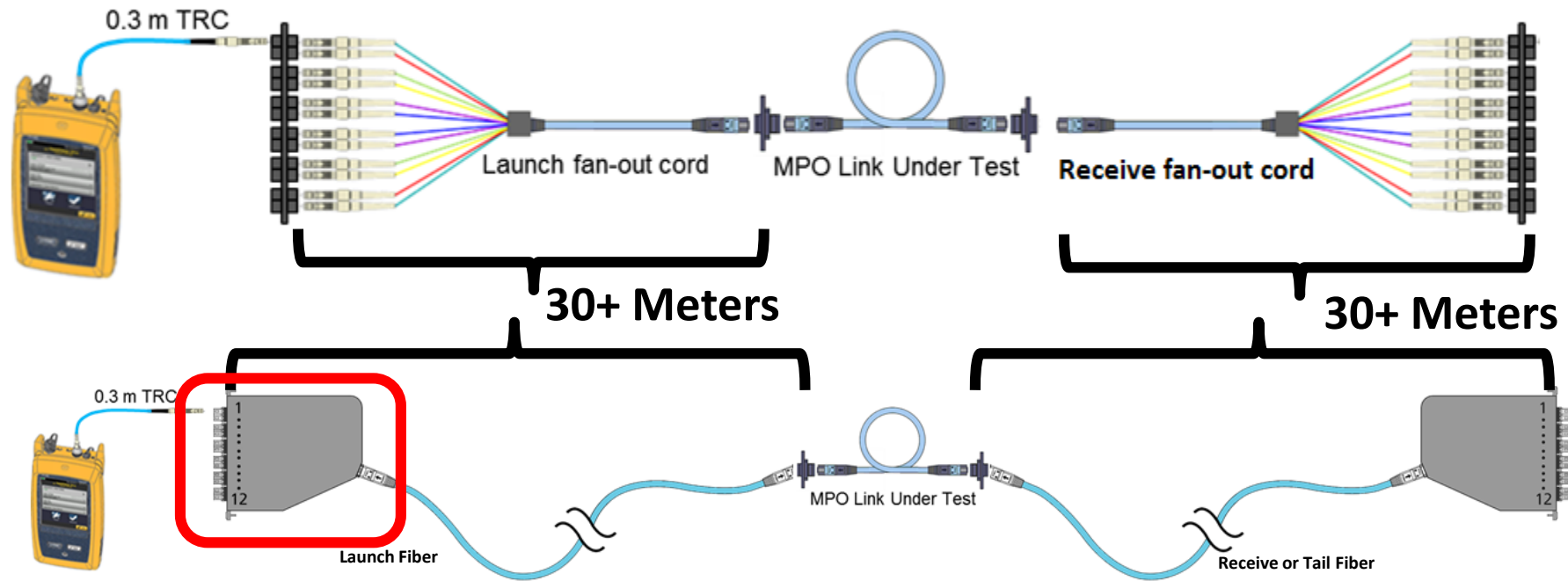



In Order to Measure the connector on the far end, you need a tail fiber

- Here we can see the end of the fiber
- There is no loss value for this connector
- The trace just ends
- One Solution is to shoot the trace from the other end
- Here we see that this is End 2
- It looks like it is failing for too much loss
- Which is a great lead-in to Bi-Directional testing





Bi-Directional Averaging

- An OTDR expects the fiber to have the same “backscatter co-efficient” for the whole length of the fiber
 - Notice the nice smooth Raleigh Scattering
- But in the real world, you may have to connect two fibers together, that are both good, but that have a slightly different properties
 - Notice the Gainer
- Here we see the Gainer in the Expert Module
 - Notice the negative loss
- Oh No! A Failing connection, too much loss
- Perhaps not though





Variations in Backscatter Co-Efficient drive the need for Bi-Directional Testing with an OTDR

- OTDRs determine event loss based on variations in the amount of reflected light (Rayleigh Scattering) received
 - Typically, there is less reflected light received after an event, suggesting loss
- In this example, the attached fiber has more backscatter

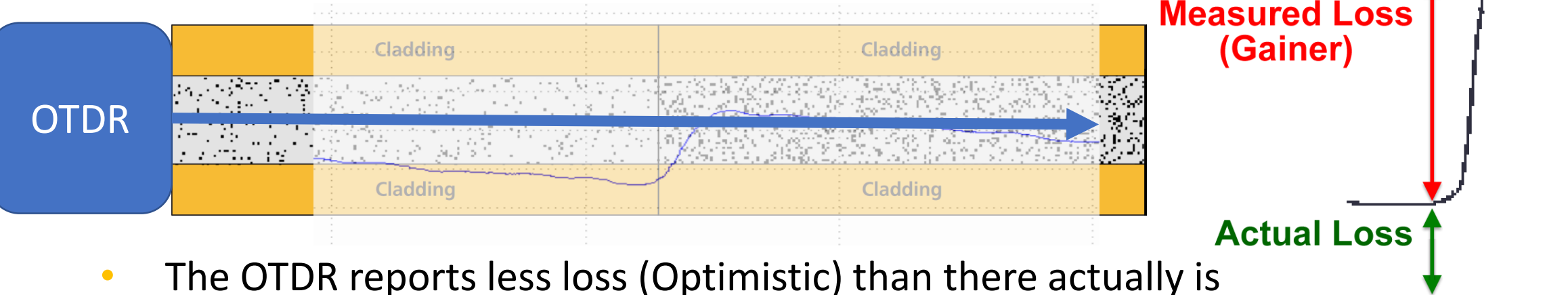

- The OTDR reports less loss (Optimistic) than there actually is
- This can result in a negative loss (gainer) as shown here



What Goes Up...

- OTDRs determine event loss based on variations in the amount of reflected light (Rayleigh Scattering) received
- In this example, the attached fiber has less backscatter

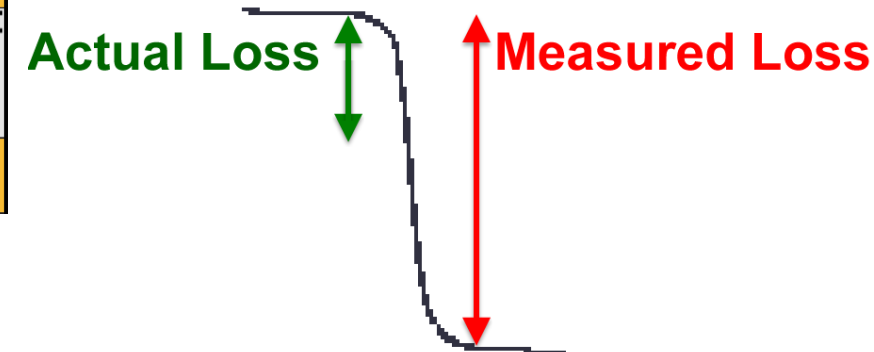
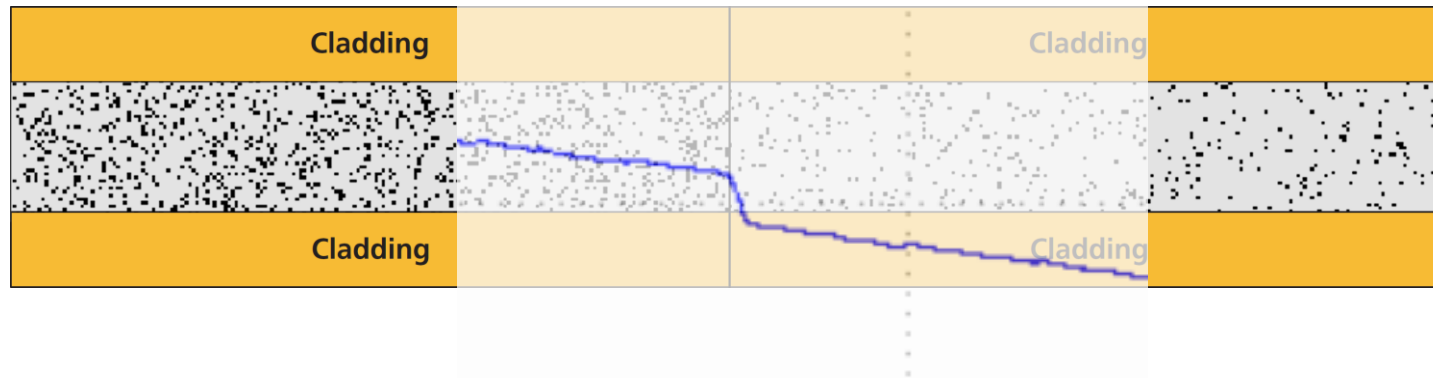

- The OTDR reports more loss (pessimistic) than there actually is
- This can result in a false failure
- For this reason, the OTDR trace needs to be shot in both directions and the loss values averaged to find the 'true' loss of an event



Bi-Directional Averaging

- Let's go back to the example that showed an optimistic (gainer) loss and the pessimistic loss that was failing
 - From End 2 it is 0.78 dB
- From End 1 that failing event doesn't look so bad (this is the Optimistic loss) 0.04 dB
- The correct loss for that first event is the average of the two loss values, and it is a pass, this link is fine. Nothing to fix.

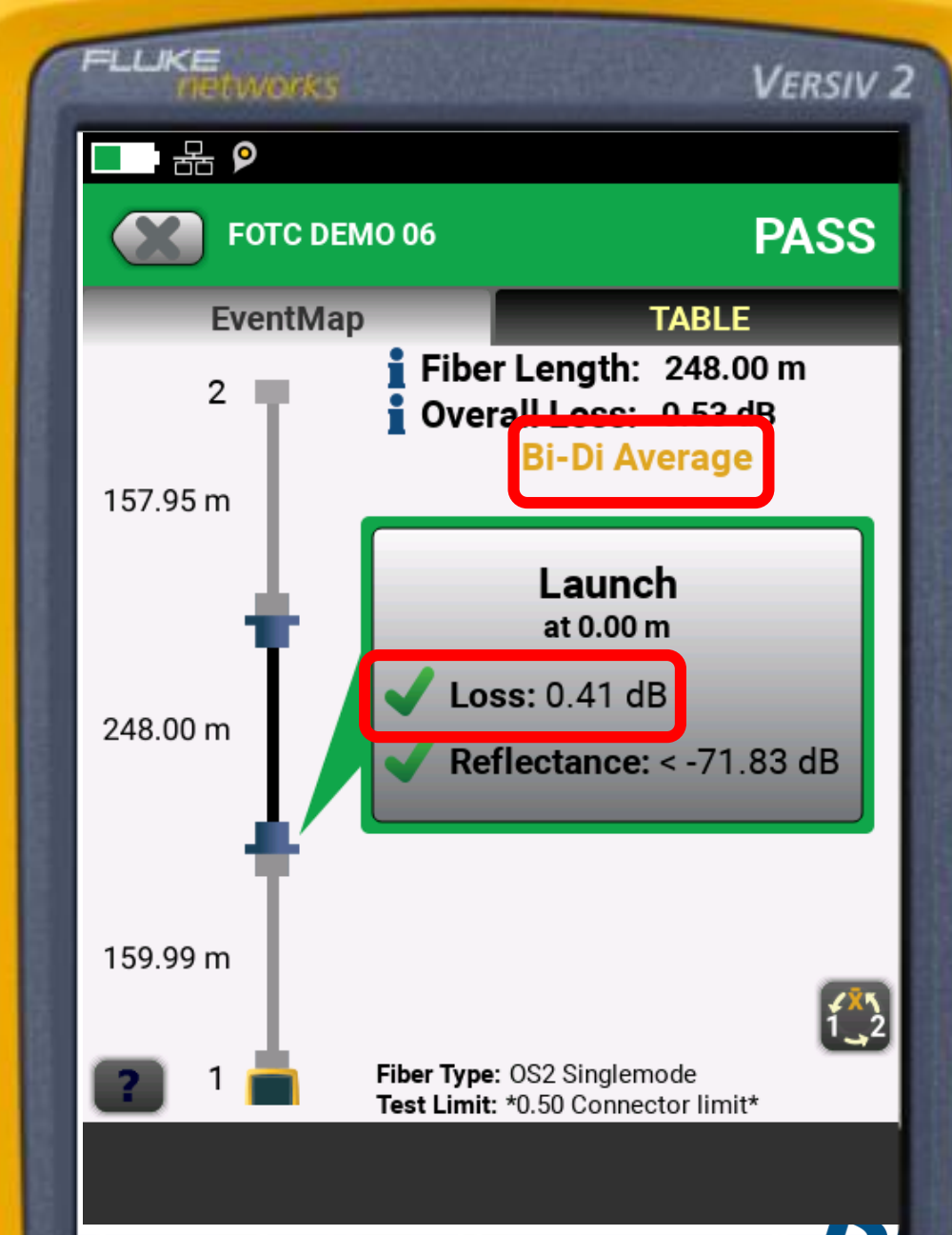



OTDRS Have a Point of View

In contrast to OLTS: A negative loss is not a sign for poor practices it the name of the game and a bi-directly test is always needed

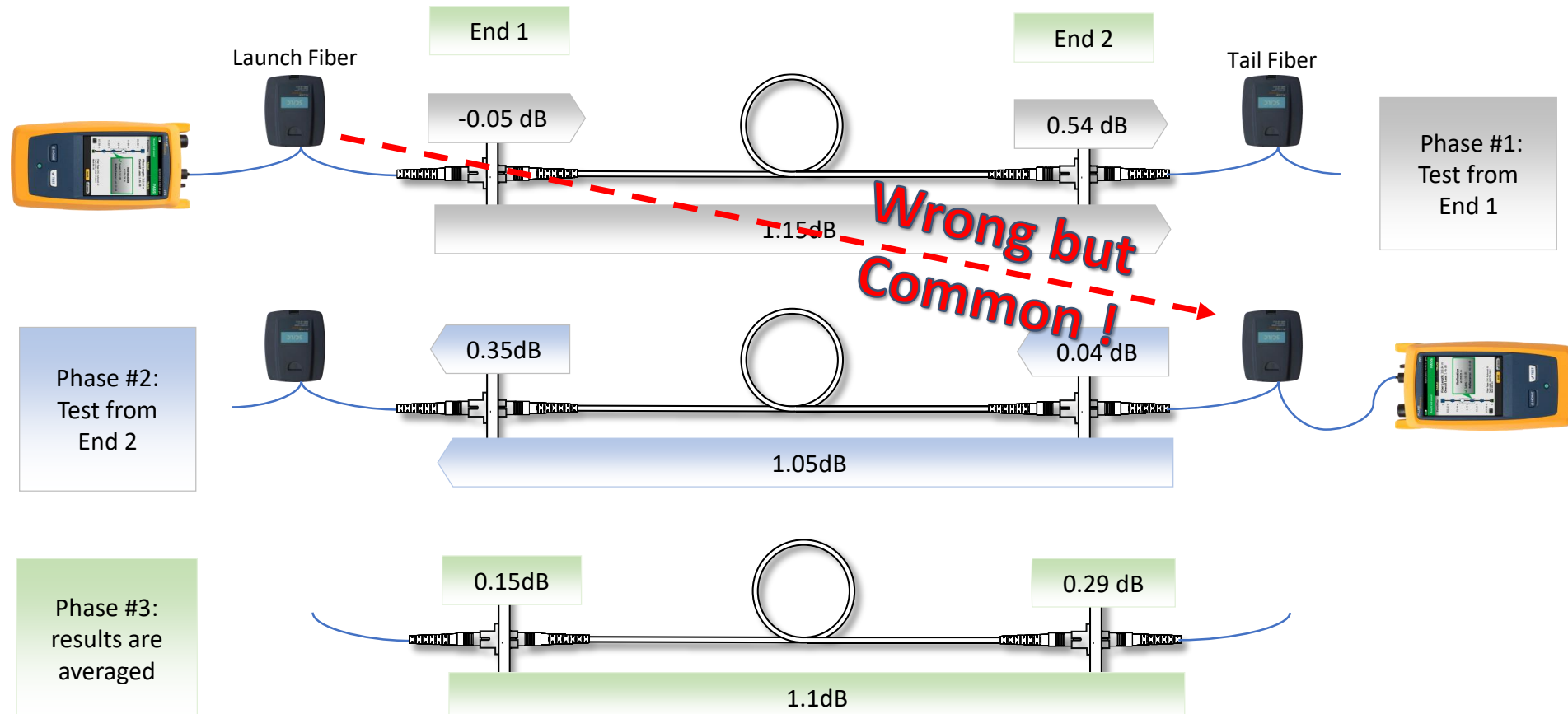



A method to get it always right is to use a LOOP

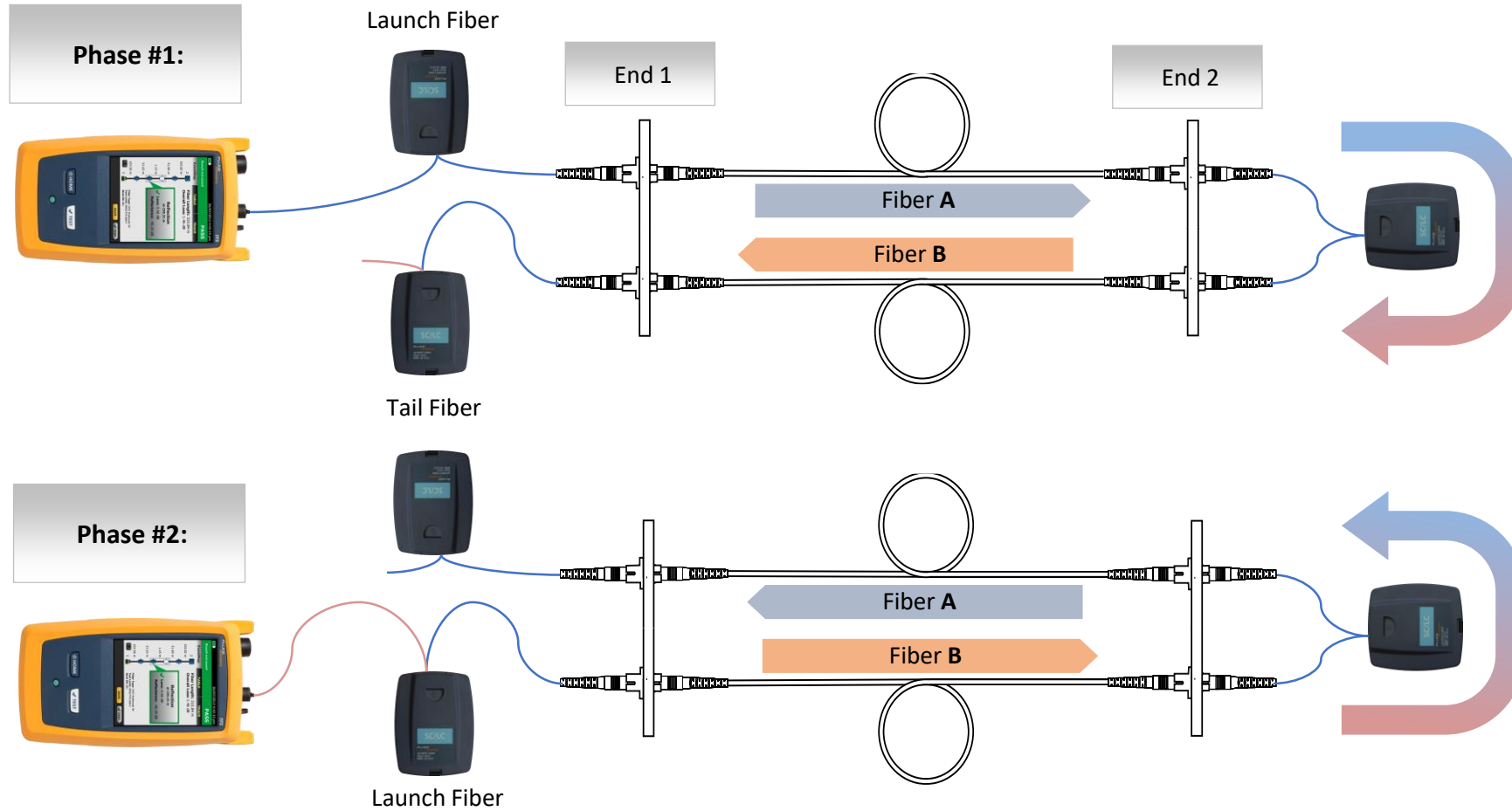



Concept of “Smart” Loop Testing

- The OTDR automatically identifies Fiber A and B for both both test
 - From End 1
 - From End 2
- The OTDR saves 4 test results in one pass
- The OTDR automatically learns the correct lengths of Launch / Loop / Tail Fibers

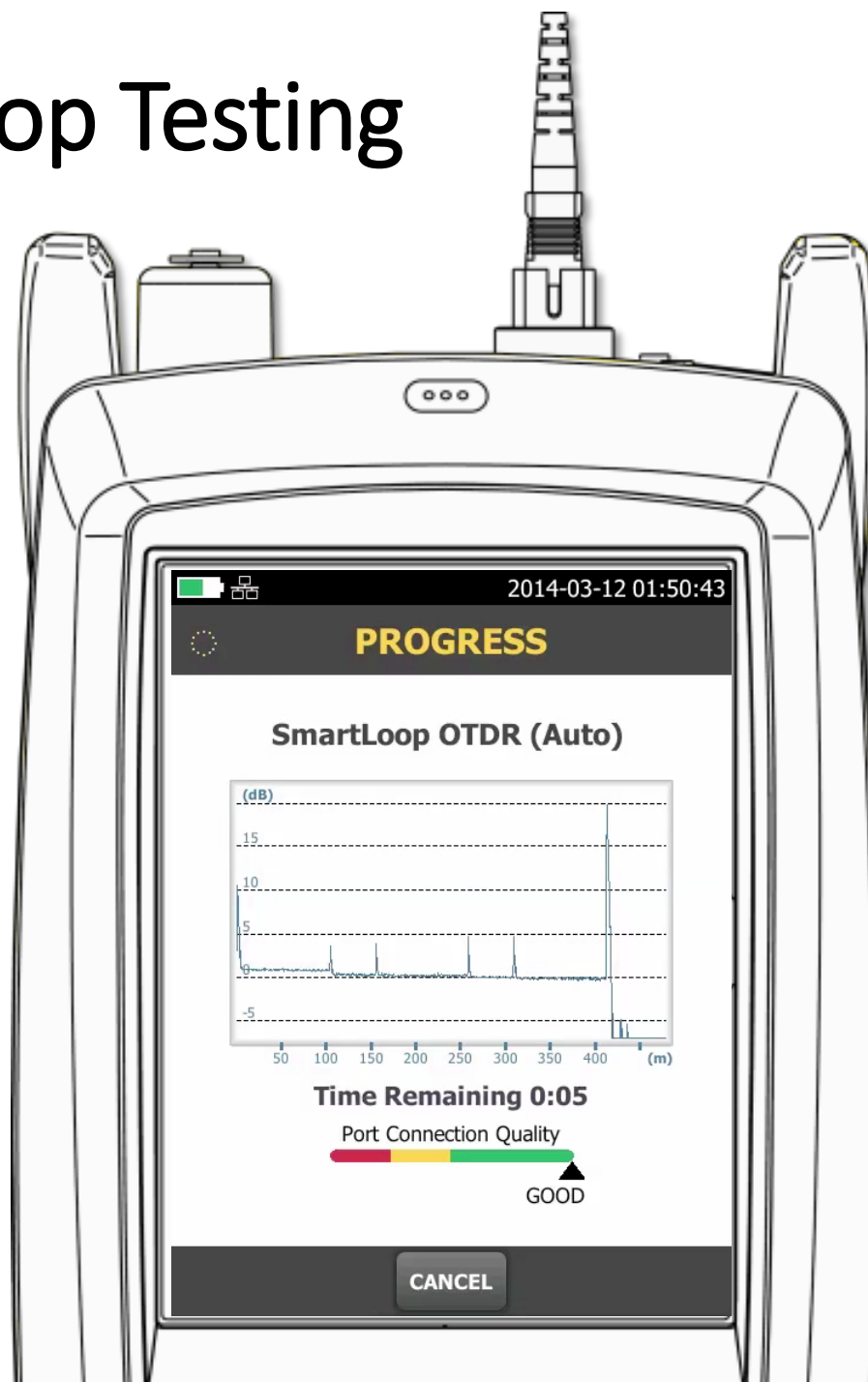



What is the distance to the end or a break in the fiber?

- [Image of a dog with a fiber optic cable in its mouth]
- [Text: s for a the length]
- [Text: ber is the known or IOR]
- [Text: ange the]
- [Text: 6478 m]
- Where is the break? Discuss





Pick a limit with Reflectance

- Reflectance is not a mandatory value in the TIA-568 limit or General Fiber
- Pick the limit that is correct for your connectors and your applications
- Look at this nice Passing Result
- Someone asked me at a recent Bicsi show, “What is a Ghost Source”
- It is an event with Terrible Reflectance
 - Did you notice?
 - This limit doesn't have a reflectance requirement so it doesn't pass or fail
 - May be caused by poor polish or dirt
- If you use a limit with reflectance limits, you will be more likely to see this failure in the field without having to look at the trace

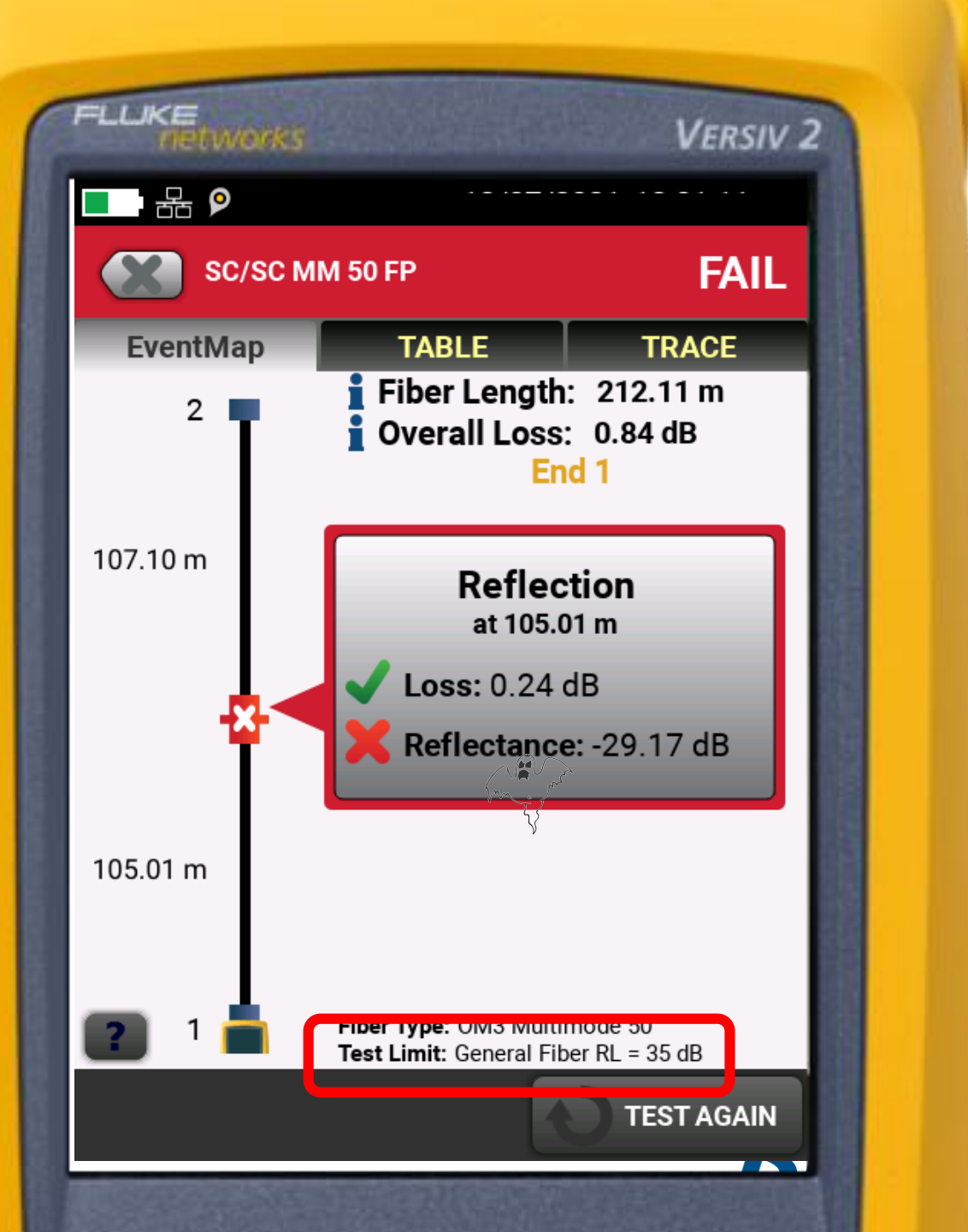



There are more topics we could cover, but not today

- Manual Settings
 - Pulse Width
 - Averaging time
- Bend
- UPC Vs APC
- Splitter
- An example of Core Size Mismatch? 50 v 62.5?
 - Is this still a valid issue?
- And more!



Summary of Today's Learning

- Tools to use before
- If you have to use
• The person who
- Launch and Tail

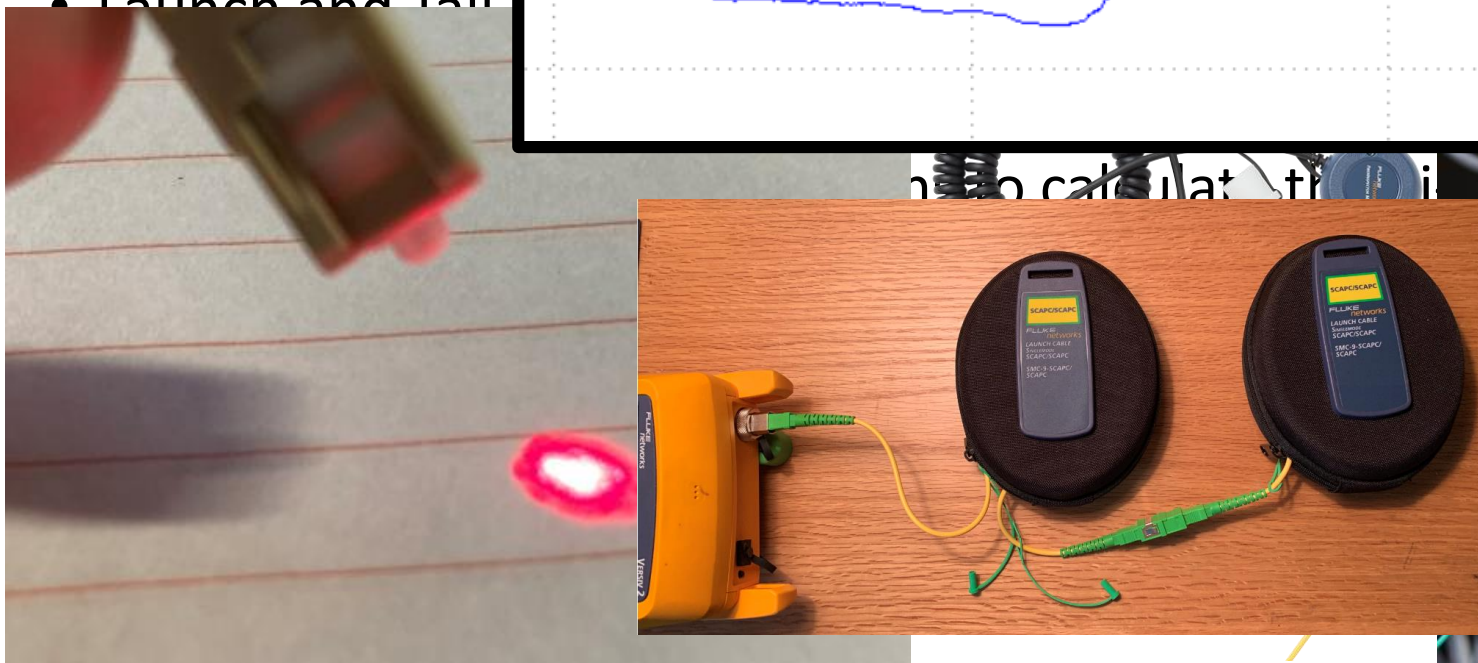
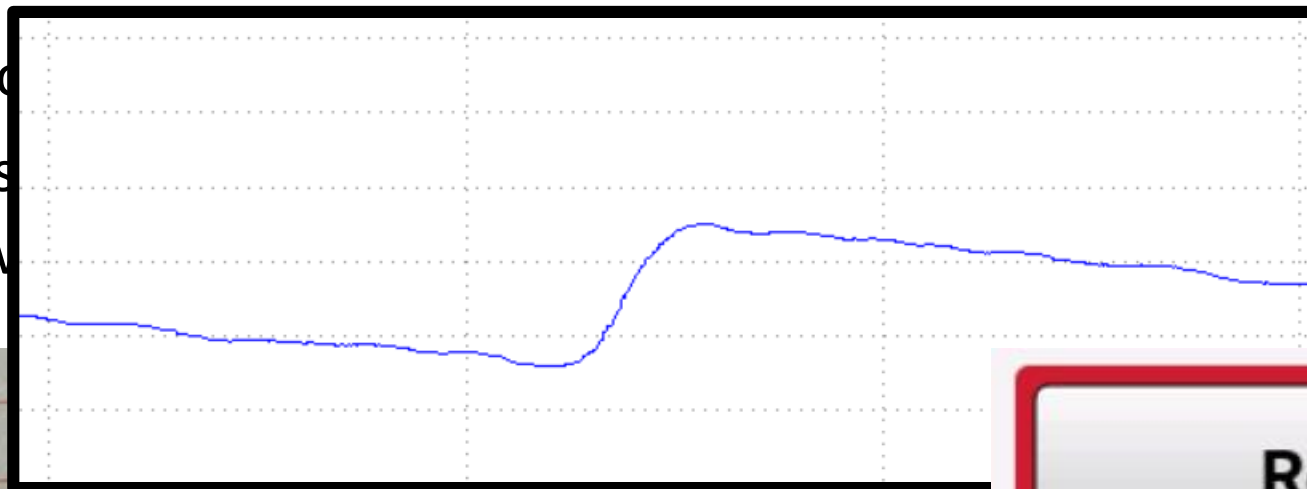

Reflection
at 105.01 m

✓ Loss: 0.24 dB

✗ Reflectance: -29.17 dB



FLUKE
networks[®]

Christian Schillab

Christian.Schillab@Flukenetworks.com

